



Electronic Products and Software dedicated for the Safety of Life.

ADVANCED SOLUTIONS

Superior Technology. Superior Performance.

ESC's state-of-the-art fire security and monitoring systems are the most secure, reliable and simple systems available today.

Contact Us



+1.647.945.4025



550 Alden Road, Unit 110 Markham, ON, Canada L3R 6A8



8140898 CANADA INC. O/A. Electronic Surveillance Company



Model 8465 Demarcation Block

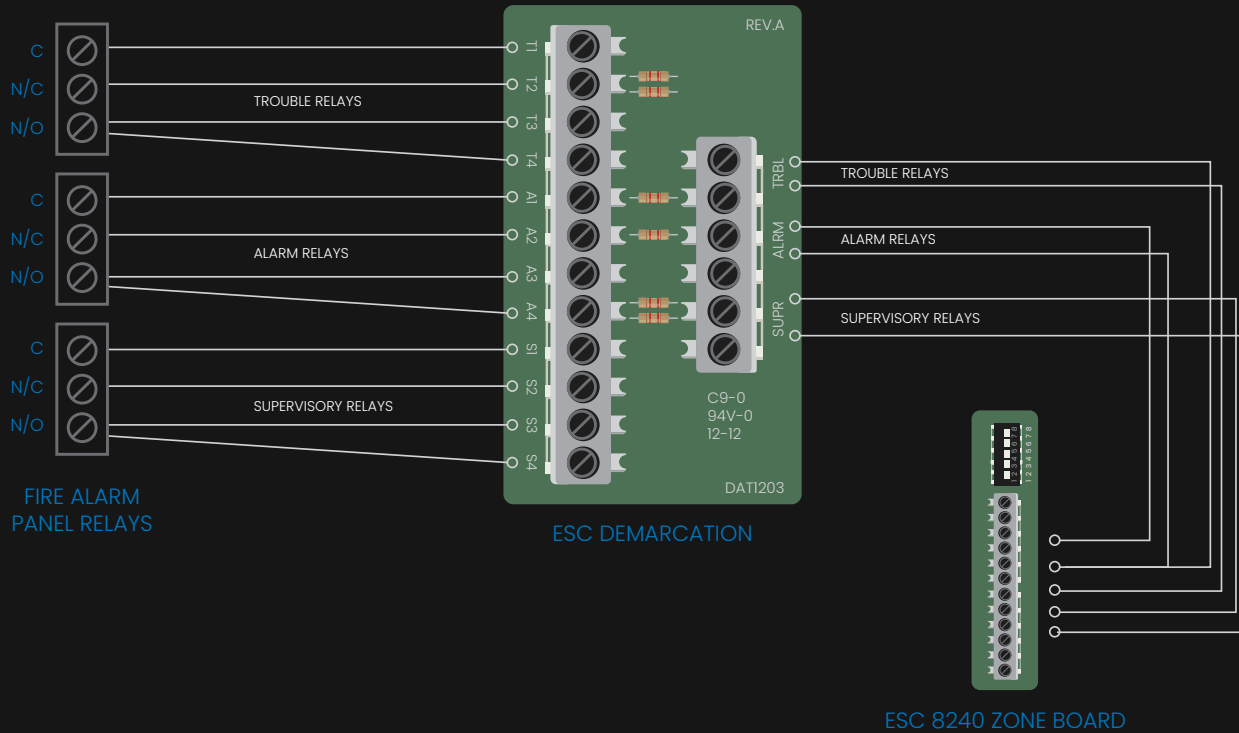

MODEL 8465

System Description

Picture depicts removable terminal blocks in a typical Fire Alarm Control Panel. Removing the terminal block will cause a trouble condition on the transmitter.

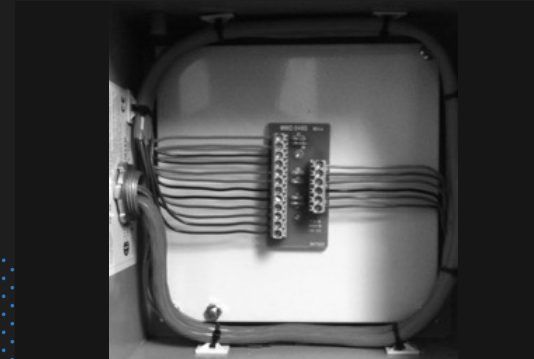

TYPICAL INSTALLATION*